

VALVOLE A GLOBO SERIE L20-A2
GLOBE VALVES SERIES L20-A2



DESCRIZIONE

L20-A2 è una valvola due vie a singolo seggio con flusso avviato, disegnata per offrire una gamma completa di valvole di controllo di fluidi come vapore, acqua, olio, e per fluidi industriali in generale. L'elevato valore di rangeability, la progettazione modulare e la flessibilità di questa serie, permettono di soddisfare le molteplici necessità di controllo dei processi industriali dai più semplici ai più gravosi. Innumerevoli configurazioni sono disponibili, come: passaggi ridotti, trim antirumore ed anticavitazione, per soddisfare tutte le esigenze di controllo e di regolazione

CARATTERISTICHE COSTRUTTIVE

- Da ½'' a 8'' ANSI 600
- Otturatore guidato "Top Guide" standard per garantire maggior stabilità
- Morsetto CEI EN 60534-6-1 std (ex.IEC534)
- Packing a doppia tenuta
- Classe di tenuta disponibili :
 - IV (Std)
 - V
 - VI

DESCRIPTION

Manufactured under ISO 9001 quality assurance system, the MEC-RELA L20-A2 series is a top entry globe valve style body construction with a wide range of different single stage trims available. L20-A2 series combine the advanced modular design and the wide range of actuators to satisfy the needs of the industrial demand.

L20-A2 valves are designed to control a broad variety of fluids, like steam, water, most of the medium and gases. One of the main features of this series is the top guided construction that assure a stable plug travel over entire stroke of the valve minimizing vibration and wear.

DESIGN FEATURES

- From ½'' up to 8'' ANSI 600
- Top Guided std construction to ensure plug stability
- CEI EN 60534-6-1 clamp Std (ex.IEC534)
- Double V-Ring packing spring loaded
- Shutoff capabilities:
 - IV (Std)
 - V
 - VI

OPZIONI

- Passaggi ridotti su misura
- Interni stellati per pressione differenziale elevata
- Otturatori bilanciati per alte pressioni
- Gabbie antirumore e anticavitazione
- Otturatori a microflusso per basse portate
- Packing con soffiello di tenuta per emissioni "ZERO" (ZEB20)
- Bonnet allungato per basse temperature
- Bonnet alettato per alte temperature
- Gamma completa di accessori (posizionatori, ritrasmissione, lock -up, contatti di allarme, etc...)
- Costruzione conforme NACE0175/2003 o ISO15156 (su richiesta)
- Terminali a saldare

OPTIONS

- Reduced area trim to provide wide capabilities for all sizes
- Hardened trims to handle high pressure drop applications.
- Balanced trims to handle high pressure drop & shutoff
- Low noise & anticavitation design cage
- Reduced capacity & low flow trim in all sizes
- Bellows seal to meet zero emissions (ZEB20)
- Extended bonnet for low temperature
- Finned bonnet for high temperature
- Available accessories : positioners, position transmitter, limit switches, lock-up etc
- NACE0175/2003 or ISO15156 Construction on request
- Butt Welding ends / Socket Welding ends

LEGENDA

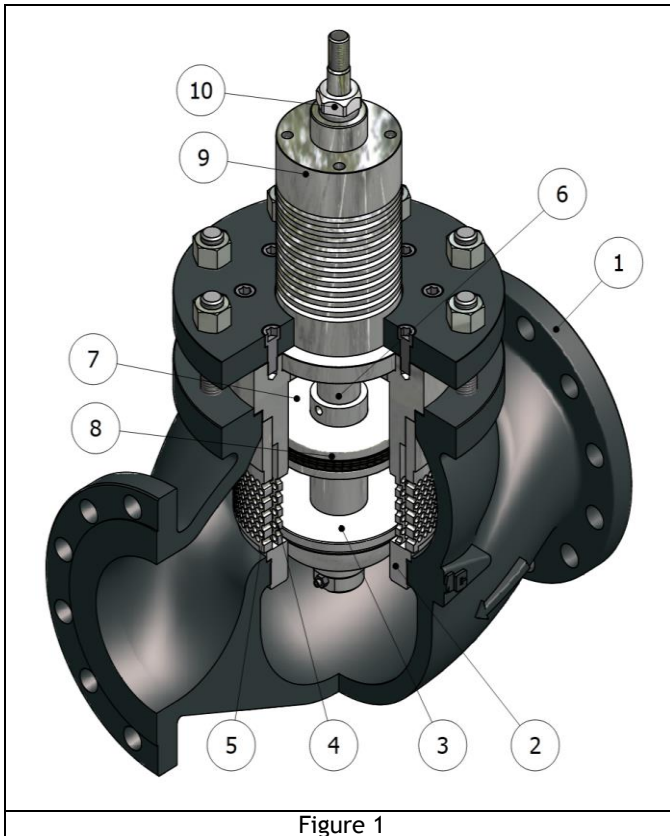

Figure 1

1. Corpo valvola
2. Sede
3. Otturatore
4. Prima gabbia antirumore
5. Seconda gabbia antirumore
6. Stelo Top-Guide
7. Camera di bilanciatura
8. Pistone di bilanciatura
9. Bonnet
10. Premistoppa

LEGEND

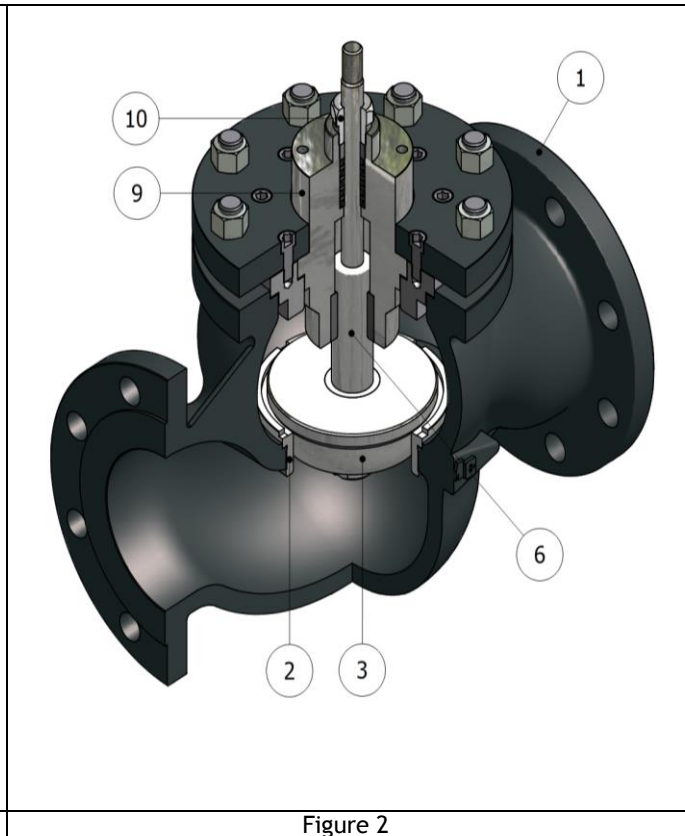

Figure 2

1. Body valve
2. Seat ring
3. Plug
4. 1st low dB anti-cavitation cage
5. 2nd low dB anti-cavitation cage
6. Top-Guide stem
7. Balancing sleeve
8. Balancing piston
9. Valve bonnet
10. Stuffing box

DATI TECNICI CORPO VALVOLA

Tipo	Top entry, globo a singola sede
Diametri Nominali	½" fino a 8"
Rating del Corpo	ANSI 600
Costruzione	ANSI B16.34
Flange	ANSI B16.5, Cl. 600 RF
Scartamento	ANSI / ISA 75.08.01

MATERIALI GRUPPO CORPO STD

Corpo valvola: Acciaio al Carbonio A216 WCC	Bonnet: da 1/2" a 4" ASTM A105; da 6" a 8" A216 WCC Interni: ASTM A182 F316
Corpo valvola: Acciaio Inox A351 CF8M	Bonnet: da 1/2" a 4" ASTM A182 F316; da 6" a 8" A351 CF8M Interni: ASTM A182 F316

MATERIALI DISPONIBILI SU RICHIESTA

Acciai al Carbonio	A352 LC2 - A352 LC3
	A352 LCC - A352 LCB
Acciai al Carbonio legati	A217 WC6 - A217 WC9
Acciai inossidabili austenitici	A351 CF3 - A351 CF8
	A351 CF10 - A351 CF3M
	A351 CF8M- A351 CF10M
Acciai inossidabili Ferritici austenitici	A995 CD3MWCuN - A995 A6
	A351 CK3MCuN
	A351 CE8MC
	A351 CD3MN A351 CD4MCuN
Acciai inossidabili Leghe di Nichel	A494 M35-1 (MONEL)
	A494 M35-2 (MONEL)
	A494 N-12MV (HAST. B)
	A494 CW-12MW (HAST. C)

RIVESTIMENTI PROTETTIVI STANDARD

Corpo valvola

- $-10 \leq T \leq 150^{\circ}C$
 - Fondo bicomponente acrilico anticorrosivo ad alta resistenza
 - Finitura con smalto acrilico alifatico bicomponente
 - RAL 7021
- $150 < T \leq 250^{\circ}C$
 - Fondo siliconico
 - Finitura smalto siliconico
 - RAL 9005
- $250 < T \leq 400^{\circ}C$
 - Fondo siliconico termoresistente
 - Finitura smalto siliconico
 - RAL 9006

Bonnet

- $-10 \leq T \leq 400^{\circ}C$
 - Zincatura elettrolitica Fe/Zn 8 c1A UNI ISO 4520

TRATTAMENTI PROTETTIVI SU RICHIESTA

Corpo valvola e bonnet

- Verniciatura per ambienti salini
- Verniciatura su specifica cliente

VALVE BODY FEATURES

Style	Top entry, single seated globe valve
Sizes	½" up to 8"
Pressure ratings	ANSI 600
Design STD	ANSI B16.34
Flanges connections	ANSI B16.5, Cl. 600 RF
Body dimensions	ANSI / ISA 75.08.01

STD BODY & TRIM MATERIALS COMBINATION

Carbon Steel A216 WCC	Bonnet: from 1/2" to 4" ASTM A105; from 6" to 8" A216 WCC Trim: ASTM A182 F316
Stainless Steel A351 CF8M	Bonnet: from 1/2" to 4" ASTM A182 F316; from 6" to 8" to 8" Trim: ASTM A182 F316

MATERIALS AVAILABLE ON REQUEST

Carbon steel	A352 LC2 - A352 LC3
	A352 LCC - A352 LCB
Carbon steel alloy	A217 WC6 - A217 WC9
Austenitic Stainless Steel	A351 CF3 - A351 CF8
	A351 CF10 - A351 CF3M
	A351 CF8M- A351 CF10M
Ferritic Austenitic Stainless Steel	A995 CD3MWCuN - A995 A6
	A351 CK3MCuN
	A351 CE8MC
	A351 CD3MN A351 CD4MCuN
Nickel alloy Stainless Steel	A494 M35-1 (MONEL)
	A494 M35-2 (MONEL)
	A494 N-12MV (HAST. B)
	A494 CW-12MW (HAST. C)

STANDARD PROTECTIVE COATINGS

Body valve

- $-10 \leq T \leq 150^{\circ}C$
 - Bi-component anticorrosive acrylic primer at high resistance
 - Finish with bi-component aliphatic acrylic enamel
 - RAL 7021
- $150 < T \leq 250^{\circ}C$
 - Siliconic primer
 - Finish with siliconic enamel
 - RAL 9005
- $250 < T \leq 400^{\circ}C$
 - Heat resistant siliconic primer
 - Finish with siliconic enamel
 - RAL 9006

Bonnet

- $-10 \leq T \leq 400^{\circ}C$
 - Electrolytic zinc coatings Fe/Zn 8 c1A UNI ISO 4520

PROTECTIVE COATINGS ON REQUEST

Body valve and bonnet

- Painting for sea environment
- Painting on customer specifications

SCHEDA PRODOTTO DATA SHEET

DSM-L20-A2
ED-17-12

BONNET Standard

- Temperature 23÷392 °F (-5÷200 °C)

A richiesta



- Alettato per temperature >392 °F (>200 °C)
- Allungato per temperature <23 °F (<-5 °C)

BONNET Standard

- Temperature 23÷392 °F (-5÷200 °C)

On request

- Finned for temperature >392 °F (>200 °C)
- Extended for temperature <23 °F (<-5 °C)

PROLUNGATO / EXTENDED	STANDARD	ALETTATO / FINNED
		
T < -5 °C T < 23 °F	-5 < T < 200 °C 23 < T < 392 °F	T > 200 °C T > 392 °F



RELAZIONE PRESSIONE / TEMPERATURA

RELATION BETWEEN PRESSURE/TEMPERATURE

T [°C]	ASTM A105 (-29 ÷ 425 °C)		ASTM A216 WCC (-29 ÷ 425 °C)		A182 F304 (-253 ÷ 816 °C) A182 F316 (-253 ÷ 816 °C) A351 CF8M (-253 ÷ 816 °C)	
	ANSI 150	ANSI 300	ANSI 150	ANSI 300	ANSI 150	ANSI 300
-...÷+38	19.6	51.1	19.8	51.7	19	49.6
50	19.2	50.1	19.5	51.7	18.3	47.8
100	17.7	46.6	17.7	51.5	15.7	40.9
150	15.8	45.1	15.8	50.2	14.2	37
200	13.8	38.8	13.8	48.6	13.2	34.5
250	12.1	41.9	12.1	46.3	12.1	32.5
300	10.2	39.8	10.2	42.9	10.2	30.9
325	9.3	38.7	9.3	41.4	9.3	30.2
350	8.4	37.6	8.4	40	8.4	29.6
375	7.4	36.4	7.4	37.8	7.4	29
400	6.5	34.7	6.5	34.7	6.5	28.4
425	5.5	28.8	5.5	28.8	5.5	28
450	//	//	//	//	4.6	27.4
475	//	//	//	//	3.7	26.9

TENUTA STELO

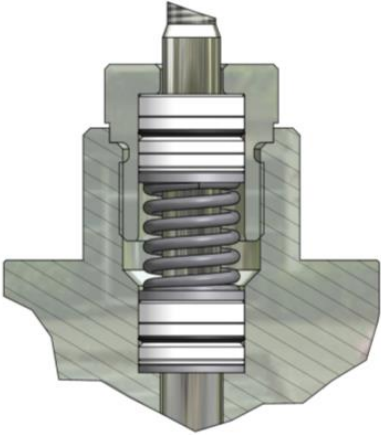
PACKING

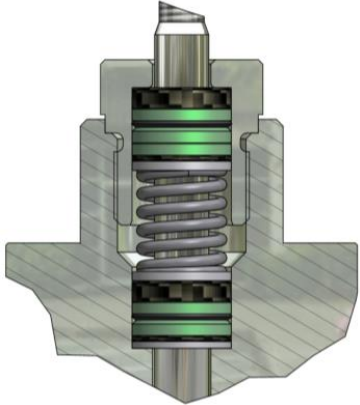
HT200	ZEB20	GREENPACK 1
		
<p>$T \leq 200^{\circ}\text{C}$ STD 1/2'' ÷ 4''</p>	<p>Soffietto per fluidi pericolosi Bellows for dangerous liquids A richiesta / On request 1/2'' ÷ 8''</p>	<p>$T \leq 450^{\circ}\text{C}$ Basse emissioni / Autoestinguente Low emissions / Firesafe A richiesta / On request 1/2'' ÷ 4''</p>

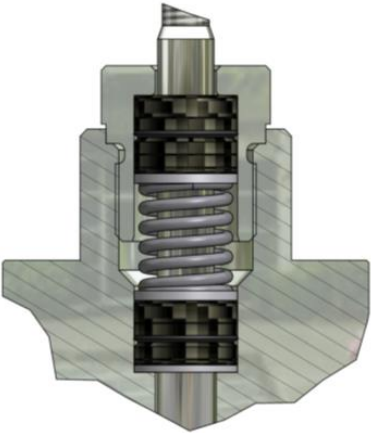
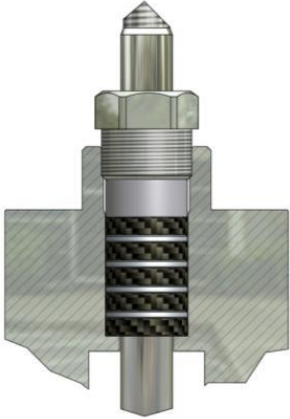
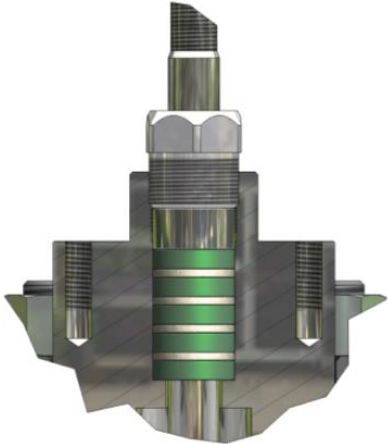
HTS300	GR20	GREENPACK 2
		
<p>$T \leq 400^{\circ}\text{C}$ A richiesta / On request 1/2'' ÷ 4''</p>	<p>$T \leq 400^{\circ}\text{C}$ Grafite pura / Pure Graphite STD 6'' ÷ 8''</p>	<p>$T \leq 450^{\circ}\text{C}$ Basse emissioni / Autoestinguente Low emissions / Firesafe A richiesta / On request 6'' ÷ 8''</p>

CARATTERISTICHE OTTURATORE

PLUG FEATURES

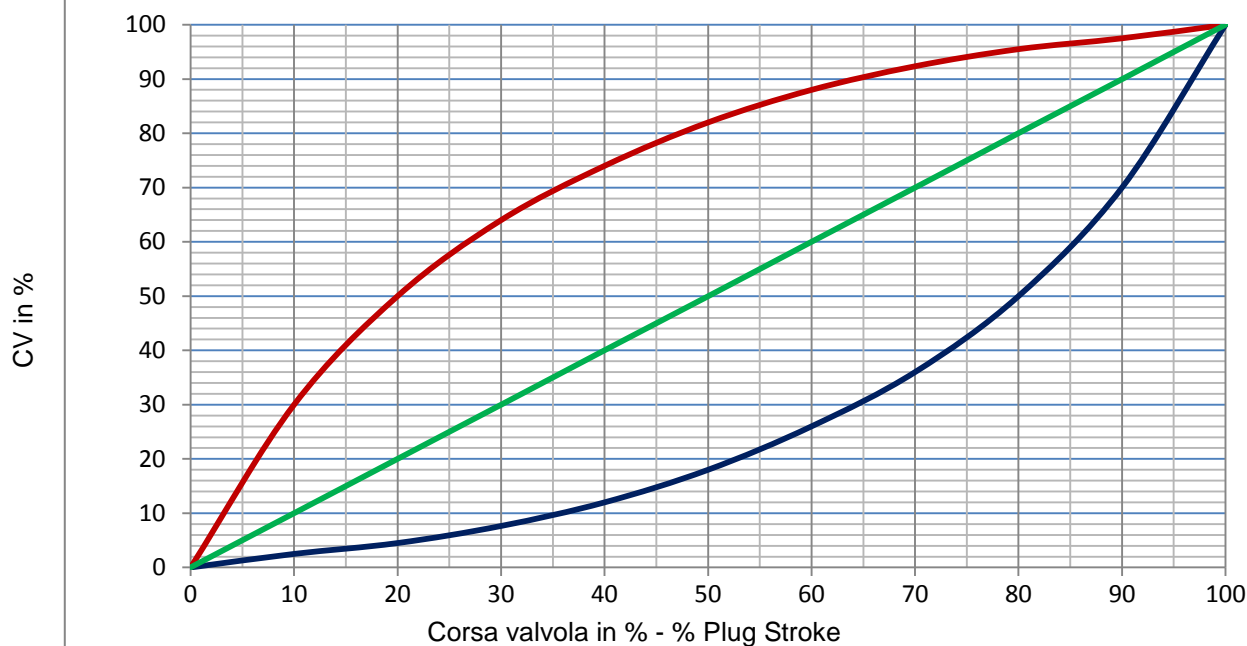

CARATTERISTICA OTTURATORE AD **APERTURA RAPIDA**

Una valvola con otturatore ad apertura rapida permette una massima variazione di portata con una corsa minima dell'otturatore e una minima variazione di portata quando l'otturatore della valvola è prossimo alla corsa massima. Le valvole con otturatore ad apertura rapida sono utilizzate spesso per applicazioni ON/OFF quando è necessario avere la massima portata nel minor tempo possibile.

QUICK OPENING FLOW CHARACTERISTIC

A valve with quick opening flow characteristic provides a maximum change in flow rate at low travels and small changes when the valve plug is near maximum. Control valves with quick opening flow characteristics are often used for on/off applications where significant flow rate must be established quickly as the valve begins to open. Consequently they are often used in relief valve applications. Quick opening valves can also be selected for many of the same applications for which linear flow characteristics are recommended.

CARATTERISTICA OTTURATORE **LINEARE**

Una valvola con otturatore lineare fornisce una portata direttamente proporzionale alla corsa dell'otturatore. Le valvole con questa caratteristica sono frequentemente specificate per applicazioni liquido-livello e controllo di portata.

LINEAR CHARACTERISTIC

A valve with linear characteristic provide a flow rate directly proportional to travel. Linear characteristics are commonly specified for liquid-level and flow-control applications.

CARATTERISTICA OTTURATORE **EQUIPERCENTUALE**

Nella caratteristica equipercentuale, a pari incremento di corsa dell'otturatore si ottiene una variazione equipercentuale della portata. Una valvola con questa caratteristica fornisce una precisione di controllo partendo da una minima corsa dell'otturatore e aumenta rapidamente la portata di efflusso quando è vicina alla massima apertura. Valvole con otturatore a caratteristica EQP sono le più utilizzate per applicazioni di controllo di pressione, per applicazioni quando una larga percentuale di caduta di pressione è normalmente assorbita dal sistema stesso e solo una minima percentuale deve essere controllata, e dove si possono avere grandi variazioni di pressione.

EQUAL PERCENTAGE FLOW CHARACTERISTIC

In equal percentage flow characteristic, equal increments of valve travel produce equal percentage changes in the existing flow. A valve with an inherent equal percentage flow characteristic provides precise throttling control through the lower portion of the travel range and rapidly increasing capacity as the valve plug nears the wide open position. Valves with equal percentage flow characteristics are used on pressure control applications, on applications where a large percentage of the pressure drop is normally absorbed by the system itself with only a relatively small percentage available at the control valve, and on applications where highly varying pressure drop conditions can be expected.





**SCHEDA PRODOTTO
DATA SHEET**

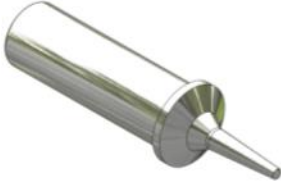
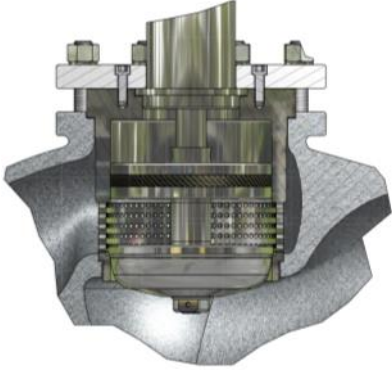

**DSM-L20-A2
ED-17-12**

TRIMS	
TENUTA	Metallica - Classe IV
PROFILO OTTURATORE	Equipercentuale (EQP)
	ON/OFF (PT)
	Lineare (PL)
PASSAGGIO	Integrale
A RICHIESTA	Passaggio ridotto
	Passaggio micro-flusso
	Stellittatura sede / ottur. Cl. IV
	Tenuta soffice PTFE \leq 150°C - Cl. VI
	Tenuta soffice PTFE/GR \leq 190°C - Cl. VI

TRIMS	
SEAL	Metal seat tightness - Cl- IV
PROFILO OTTURATORE	Equal percentage (EQP)
	ON/OFF (PT)
	Linear (PL)
PASSAGGIO	Full port
A RICHIESTA	Reduced port
	Micro flow port
	Stellite faced seat / plug Cl. IV
	Soft seal PTFE \leq 150°C - Cl. VI
	Soft seal PTFE \leq 190°C - Cl. VI

CORSA / STROKE			
CV Coefficiente di portata Flow rate coefficient	0.05 \div 47	73 \div 160	270 \div 650
Inches (mm)	0.79 (20)	1.18 (30)	2 (50)

Microflusso / Spline trim CV \geq 0.05	Otturatore bilanciato con gabbia anti-cavitazione e/o riduzione rumore Balanced trim with cage noise reduction and / or anti-cavitation	Apertura rapida Quick-opening trim
		
Equipercentuale a tenuta soffice Equi percentage soft tightness		Equipercentuale a tenuta metallica Equi percentage metal tightness
		



Gabbia per riduzione rumore singolo stadio Low dB trim single stage	Gabbia per riduzione rumore doppio stadio Low dB trim double stage	Gabbia anticavitazione Anti-cavitation cage
		

**SCHEDA PRODOTTO
DATA SHEET**

**DSM-L20-A2
ED-17-12**

COEFFICIENTI DI PORTATA

FLOW RATE COEFFICIENTS

CV	Kv	Foro sede [mm] Seat hole [mm]	DIAMETRO NOMINALE / SIZES									
			1/2"	3/4"	1"	1 1/2"	2"	3"	4"	6"	8"	
0.05÷4	0.04÷3.5	3÷10	OnReq	OnReq	OnReq							
4.5	3.8	15	STD	OnReq	OnReq	OnReq						
6	5.1	20		STD	OnReq	OnReq	OnReq					
11	9.4	25			STD	OnReq	OnReq					
18	15.4	30				OnReq	OnReq	OnReq				
27	22.2	38				STD	OnReq	OnReq	OnReq	OnReq		
47	40.1	49					STD	OnReq	OnReq	OnReq		
73	63.4	64						OnReq	OnReq	OnReq		
105	89.7	76						STD	OnReq	OnReq	OnReq	
160	136.7	96							STD	OnReq	OnReq	
190	160	100							OnReq	OnReq	OnReq	
270	230.8	126								OnReq	OnReq	
370	316.2	151									STD	OnReq
650	555	201										STD
		Kv=Portata in m3/h con 1 bar di ΔP / Flowrate in m3/h with 1 bar of ΔP										
		CV=Portata in GPM con 1 psi di ΔP / Flowrate in GPM with 1 psi of ΔP										
STD	Standard											
OnReq	A richiesta / On Request											

SCHEDA PRODOTTO DATA SHEET

DSM-L20-A2
ED-17-12

ATTUATORE PNEUMATICO DI REGOLAZIONE

CONTROL PNEUMATIC ACTUATOR

Pressioni differenziali massime ammissibili in Bar (Fluido Apre) per costruzioni con otturatori non bilanciati.
Maximum admissible pressure drops in Bar (FluidOpen) for unbalanced construction.

Attuatore Actuator	Segnale Signal [psi]	CV 4.5		CV 6		CV 11		CV 18		CV 27		CV 47		CV 73		CV 105		CV 160 CV 190		CV 270		CV 370		CV 650	
		IV	VI	IV	VI	IV	VI	IV	VI	IV	VI	IV	VI	IV	VI	IV	VI	IV	VI	IV	VI	IV	VI	IV	VI
AP23	3÷15	15	21	14	18	9	12	5	8	3	4	2	3	-	-	-	-	-	-	-	-	-	-	-	-
	6÷18	18	26	16	22	11	17	7	10	4	5	3	4	-	-	-	-	-	-	-	-	-	-	-	-
	6÷30	50	60	22	28	16	25	10	15	6	8	4	6	-	-	-	-	-	-	-	-	-	-	-	-
	15÷60	70	80	45	60	35	56	27	33	15	17	8	12	-	-	-	-	-	-	-	-	-	-	-	-
AP28	3÷15	31	35	27	30	17	26	8	15	6	9	4	6	-	-	-	-	-	-	-	-	-	-	-	-
	6÷18	40	45	38	40	21	30	13	19	10	12	5	8	-	-	-	-	-	-	-	-	-	-	-	-
	6÷30	55	60	50	55	26	47	23	26	12	16	7	12	-	-	-	-	-	-	-	-	-	-	-	-
	15÷60	99	99	80	90	48	75	40	56	25	38	17	23	-	-	-	-	-	-	-	-	-	-	-	-
AP34 / AP35	3÷15	60	65	60	65	50	55	20	23	12	18	10	16	4	4	2	3	1	1	-	-	-	-	-	-
	6÷18	80	85	80	85	60	65	30	35	15	18	12	15	6	7	4	5	2	3	-	-	-	-	-	-
	6÷30	99	99	99	99	80	85	40	45	20	25	14	16	7	8	5	6	2	3	-	-	-	-	-	-
	15÷60	-	-	-	-	-	-	62	65	36	45	25	29	11	13	8	11	6	6	-	-	-	-	-	-
AP43 / AP44	3÷15	-	-	-	-	-	-	-	-	35	40	24	26	7	8	6	6	4	4	-	-	-	-	-	-
	6÷18	-	-	-	-	-	-	-	-	40	45	26	28	9	10	8	8	5	5	-	-	-	-	-	-
	6÷30	-	-	-	-	-	-	-	-	40	45	26	28	12	12	10	10	6	6	-	-	-	-	-	-
	15÷60	-	-	-	-	-	-	-	-	60	85	40	70	28	37	22	27	15	17	-	-	-	-	-	-
AP45	15÷60	-	-	-	-	-	-	-	-	60	85	40	70	28	37	22	27	15	17	-	-	-	-	-	-
AP46	15÷60	-	-	-	-	-	-	-	-	-	-	-	-	-	-	-	-	-	-	7	8	5	6	3	4
AP60	15÷60	-	-	-	-	-	-	-	-	-	-	-	-	-	-	44	54	30	34	14	16	10	12	6	8

Cl. IV	Tenuta metallica - Classe IV° - ANSI FCI 70-2 / Metal seat tightness - Class IV° - ANSI FCI 70-2
Cl. IV	Tenuta soffice - Classe VI° - ANSI FCI 70-2 / Soft seal- Class VI° - ANSI FCI 70-2

I valori espressi in tabella si riferiscono alla forza del servomotore, il rating del corpo ne limita l'applicazione.
The pressure drop values must be used within the body rating limit.

ATTUATORE PNEUMATICO DI REGOLAZIONE

CONTROL PNEUMATIC ACTUATOR

TIPO ATTUATORE / TYPE	Multimolla a membrana / Multispring diaphragm type
SEGNALI DI COMANDO / CONTROL SIGNAL [psi]	3÷15 6÷18 6÷30 15÷60
P_{MAX}	3.5 bar - 50 psi 6 bar - 87 psi
TEMPERATURA AMBIENTE / AMBIENT TEMPERATURE	-20÷+70 °C
MATERIALE CUSTODIA / HOUSING MATERIAL	Acciaio Al Carbonio / Carbon Steel Fe410.1
CASTELLO / YOKE MATERIAL	Integrale / Integral ASTM A216 WCB
MATERIALE MEMBRANA / DIAPHRAGM MATERIAL	NBR70
CONNESSIONI PNEUMATICHE / PNEUMATIC CONNECTIONS	1/4" NPT-F
RIVESTIMENTI PROTETTIVI / PROTECTIVE COATINGS	Verniciatura a polvere poliestere Finish powder coat polyester

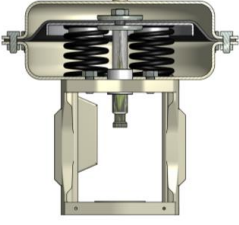
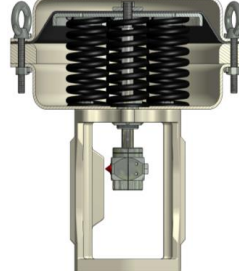
			
AZIONE DIRETTA DIRECT ACTION	Aria chiude / Air to close	AZIONE DIRETTA DIRECT ACTION	Aria chiude / Air to close

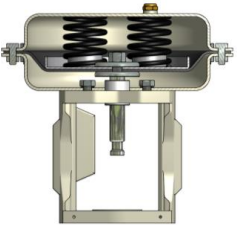
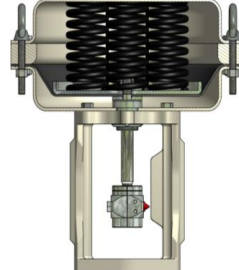
			
AZIONE INVERSA REVERSE ACTION	Aria apre / Air to open	AZIONE INVERSA REVERSE ACTION	Aria apre / Air to open

ACCESSORI DISPONIBILI

- Contatti di allarme
- Posizionatore elettropneumatico
- Posizionatore pneumatico
- Posizionatore Smart
- Convertitore I/P
- Trasmittitore di posizione 4÷20 mA
- Filtro riduttore
- Volantino di manovra
- Elettrovalvole
- Dispositivo pneumatico di blocco (Lock Up)

VARIANTI DISPONIBILI

- Castello Inox
- Custodia Inox
- Viteria Inox

ACCESSORIES

- Alarm contacts
- Electropneumatic positioner
- Pneumatic positioner
- Smart positioner
- I/P converter
- 4÷20 mA position feedback
- Air filter regulator
- Top mounted hand wheel
- Solenoid valves
- Lock Up pneumatic device

OPTIONS

- SS Yoke
- SS Housing
- SS Bolts & Nuts

SCHEDA PRODOTTO DATA SHEET

DSM-L20-A2
ED-17-12

DIMENSIONI

DIMENSIONS

SIZE	A inches (mm)	B inches (mm)	C inches (mm) BONNET			C inches (mm) BONNET		
			Otturatore Standard / Standard Trim			Otturatore Bilanciato / Balanced Trim		
			STD	Soffietto Bellows	Alettato/prolungato Finned /Extended	STD	Soffietto Bellows	Alettato/Prolungato Finned/Extended
1/2"	8 (203,45)	1,87 (47,6)	5.08 (129)	8.98 (228)	6.81 (173)	/	/	/
3/4"	8,13 (206,45)	2,31 (58,75)	5.08 (129)	8.98 (228)	6.81 (173)			
1"	8,27 (210,05)	2,43 (61,9)	5.08 (129)	8.98 (228)	6.81 (173)			
1" ½	9,88 (251)	3,06 (77,8)	5.04 (128)	8.90 (226)	7.28 (185)	6,18 (157)	10,07 (256)	8,42 (214)
2"	11,26 (286)	3,25 (82,55)	5.04 (128)	8.90 (226)	7.28 (185)	6,18 (157)	10,07 (256)	8,42 (214)
3"	13,27 (337)	4,12 (104,75)	7.36 (187)	12.05 (306)	10.04 (260)	9,05 (230)	13,70 (348)	11,10 (282)
4"	16,01 (406,8)	5,37 (136,5)	7.24 (184)	12.09 (307)	12.20 (310)	9,64 (245)	14,48 (368)	12,20 (310)
6"	19,99 (508)	7,00 (178)	13,82 (351)	18,89 (480)		13,82 (351)	18,89 (480)	
8"	24,01 (610)	8,25 (209,6)	14,68 (373)	19,76 (502)		14,68 (373)	19,76 (502)	

SERVOMOTORE - ACTUATOR inches (mm)				AREA DI SPINTA SERVOMOTORE - ACTUATOR THRUST AREA
TIPO / TYPE	ØD	E	F	AREA inch ² (cm ²)
AP23	9,05 (230)	9,64 (245)	4,33 (110)	31,46 (203)
AP28	10,82 (275)	9,96 (253)	4,33 (110)	47,12 (304)
AP34/AP35	13,19 (335)	10,86 (276)	5,90 (150)	73,62 (475)
AP43/AP44	16,93 (430)	11,93 (303)	11,8 (300)	115,32 (744)
AP47	16,93 (430)	18,38 (476)	16,93 (430)	
AP61	23,6 (600)	19,41 (493)		

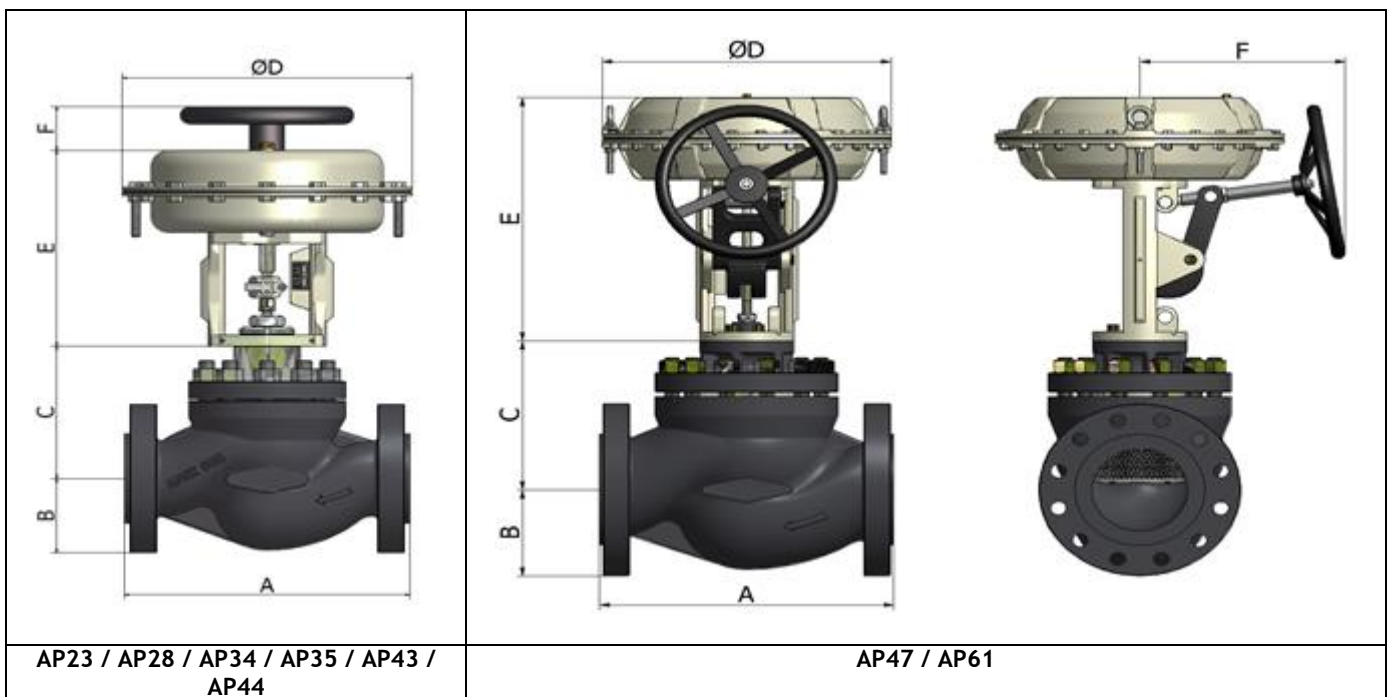

SCHEDA PRODOTTO DATA SHEET

DSM-L20-A2
ED-17-12

ATTUATORE PNEUMATICO A PISTONE

PISTON PNEUMATIC ACTUATOR

TIPO TYPE	Ø	SEGNALE SIGNAL [bar]	CV								
			0.05÷4.5	6	11	18	27	47	73	105	160
OP10	1/2''÷2''	6÷10	175 psi 12 bar	175 psi 12 bar	175 psi 12 bar	175 psi 12 bar	175 psi 12 bar	145 psi 10 bar	-	-	-
OP16	3''÷4''	6÷10	-	-	-	-	-	-	175 psi 12 bar	116 psi 8 bar	45 psi 3 bar
PRESSIONI DIFFERENZIALI MASSIME AMMISSIBILI MAXIMUM DIFFERENTIAL PRESSURE ALLOWED											

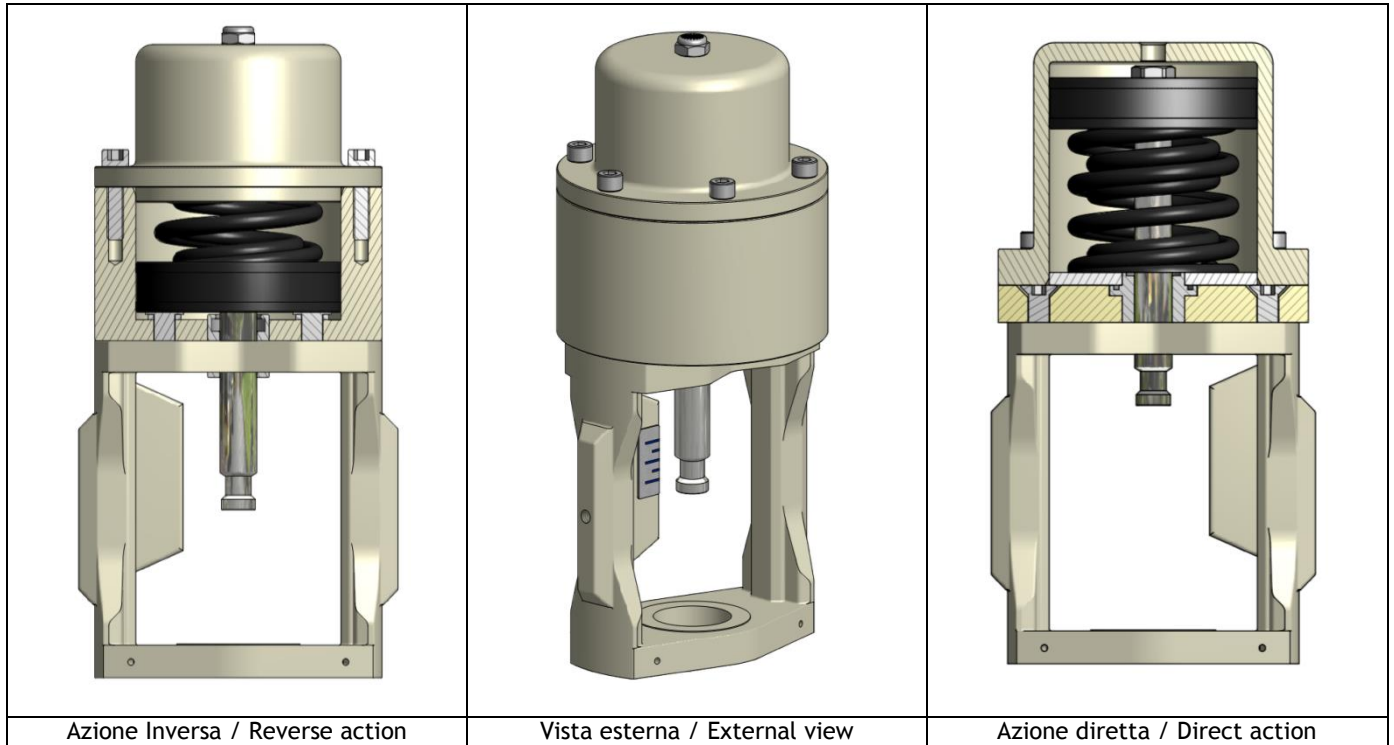

Azione Inversa / Reverse action

Vista esterna / External view

Azione diretta / Direct action

TIPO ATTUATORE / TYPE	A pistone con multimolle interne / Piston type multispring
SEGNALI DI COMANDO / CONTROL SIGNAL [psi]	90 psi ÷ 145 psi / 6 bar ÷ 10 bar
P _{MAX}	145 psi (10 bar)
TEMPERATURA AMBIENTE / AMBIENT TEMPERATURE	-4 ÷ +160 °F / -20 ÷ +70 °C
MATERIALE CASSA / CASTING MATERIAL	Alluminio verniciatura epossidica Aluminum anti-corrosive paint
CASTELLO / YOKE MATERIAL	Integrale in Acciaio Al Carbonio Integral type in Carbon Steel
CONNESSIONI PNEUMATICHE / PNEUMATIC CONNECTIONS	1/4'' NPT-F

ACCESSORI E VARIANTI DISPONIBILI

- Contatti di allarme
- Elettrovalvole
- Verniciatura per ambienti marini

OPTIONS AND ACCESSORIES

- Alarm contacts
- Solenoid valves
- Off-shore painting

SCHEDA PRODOTTO DATA SHEET

DSM-L20-A2
ED-17-12

DIMENSIONI

DIMENSIONS

SIZE	A inches (mm)		B inches (mm)		C inches (mm)		
	ANSI 150	ANSI 300	ANSI 150	ANSI 300	Otturatore Standard / Standard Trim		
					STD	Soffietto Bellows	Alettato/prolungato Finned /Extended
1/2"	7.25 (184)	7.46 (189.5)	1.87 (47.6)	1.87 (47.6)	5.08 (129)	8.98 (228)	6.81 (173)
3/4"	7.25 (184)	7.62 (194)	1.94 (49.25)	2.31 (58.75)	5.08 (129)	8.98 (228)	6.81 (173)
1"	7.25 (184)	7.75 (197)	2.11 (53.95)	2.43 (61.9)	5.08 (129)	8.98 (228)	6.81 (173)
1" 1/2	8.75 (222)	9.25 (235)	2.50 (63.5)	3.06 (77.8)	5.04 (128)	8.90 (226)	7.28 (185)
2"	10.00 (254)	10.50 (267)	3.00 (76.2)	3.25 (82.55)	5.04 (128)	8.90 (226)	7.28 (185)
3"	11.75 (298.5)	12.5 (318)	3.75 (95.25)	4.12 (104.75)	7.36 (187)	12.05 (306)	10.04 (260)
4"	13.88 (352.5)	14.50 (368)	4.5 (114.3)	5.00 (127)	7.24 (184)	12.09 (307)	12.20 (310)

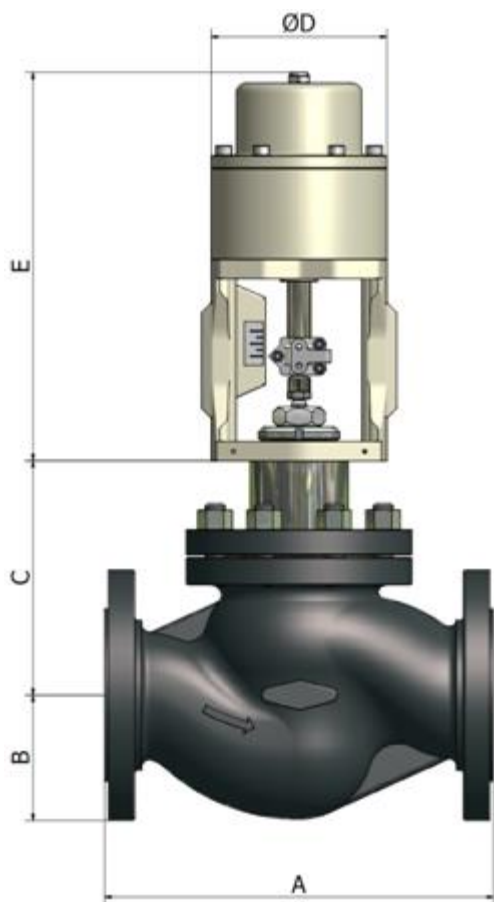

SIZE	C (mm)		
	Otturatore Bilanciato / Balanced Trim		
	STD	Soffietto Bellows	Alettato/prolungato Finned /Extended
2"	6.18 (157)	10.07 (256)	8.42 (214)
3"	9.05 (230)	13.70 (348)	11.10 (282)
4"	9.64 (245)	14.48 (368)	12.20 (310)

SERVOMOTORE / ACTUATOR inches (mm)				
TIPO / TYPE	ØD	E inches (mm)		
		3/4"÷1"1/2	2"	3"÷4"
OP10	5.51 (140)	10.51 (267)	11.50 (292)	-
OP16	7.56 (192)	-	-	13.19 (335)

SCHEDA PRODOTTO DATA SHEET

DSM-L20-A2
ED-17-12

ATTUATORE ELETTRICO

ELECTRIC ACTUATOR

TIPO ATTUATORE	Elettrico / Electrical
SEGNALI DI COMANDO	0 ÷ 10 Vdc / 2 ÷ 10 Vdc / 0 ÷ 20 mA / 4 ÷ 20 mA
SEGNALE DI USCITA	0 ÷ 10 Vdc STD
GRADO DI PROTEZIONE STD	IP54

TIPO / TYPE	FORZA / THRUST	CORSA / STROKE Inches (mm)	TEMPO AZIONAMENTO ACTUATING TIME
MC 103	1.0 kN	0.78 (20)	12 • 9 • 4 • 9 s/mm
MC 163	1.6 kN	1.18 (30)	6 • 4 s/mm
MC 253	2.5 kN	2.36 (60)	5 • 2.5 s/mm
MC 403	4.0 kN	2.36 (60)	0.6 • 0.4 s/mm
MC 503	5.0 kN	2.36 (60)	5 • 2.5 s/mm
MC 1003	10 kN	3.15 (80)	1 s/mm
MC 1503	15 kN	3.15 (80)	2 s/mm

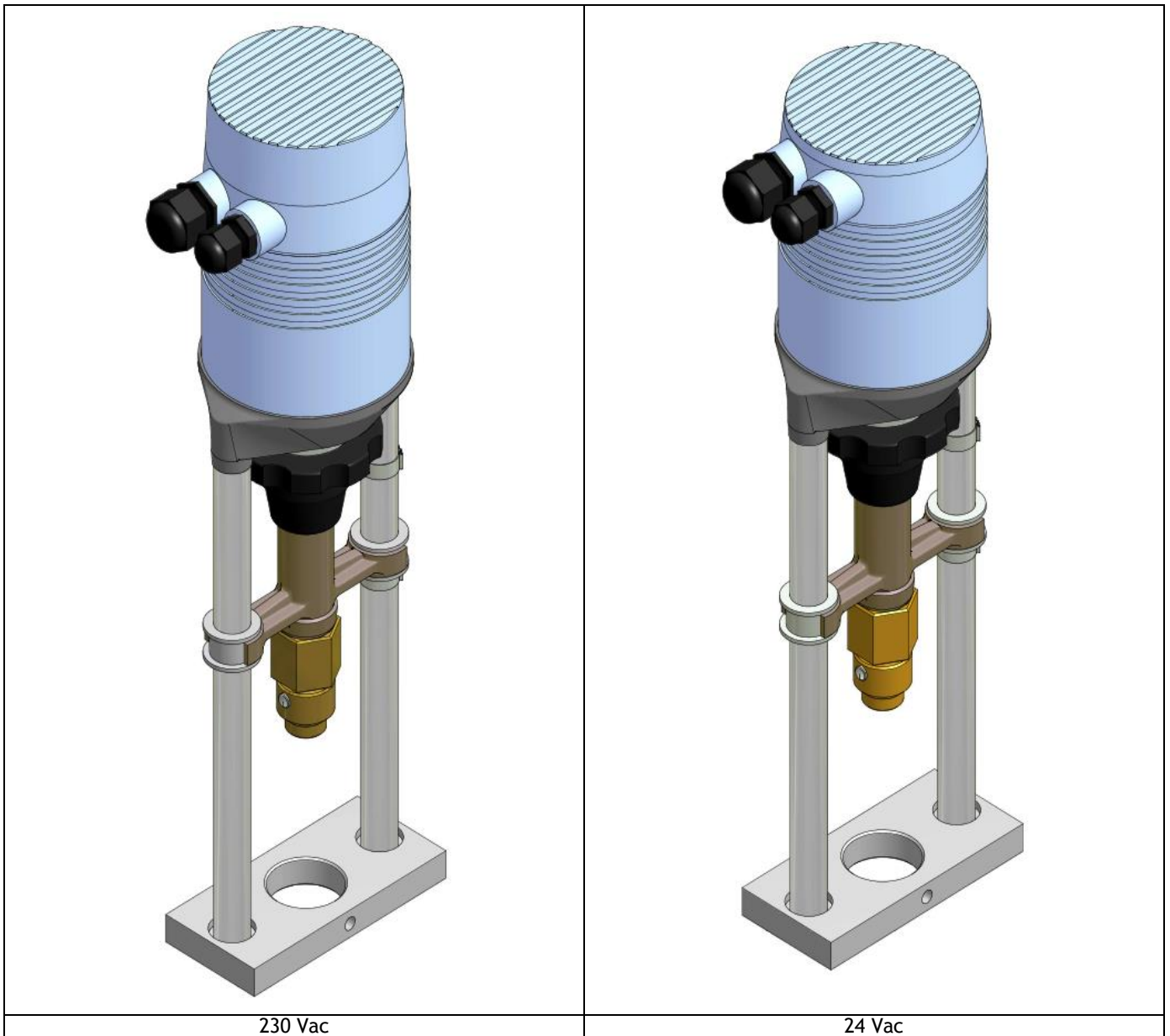

230 Vac

24 Vac

SCHEDA PRODOTTO DATA SHEET

DSM-L20-A2
ED-17-12

DIMENSIONI

DIMENSIONS

SIZE	A inches (mm)		B inches (mm)		C inches (mm)		
	ANSI 150	ANSI 300	ANSI 150	ANSI 300	Otturatore Standard / Standard Trim		
					STD	Soffietto Bellows	Alettato/prolungato Finned /Extended
1/2"	7.25 (184)	7.46 (189.5)	1.87 (47.6)	1.87 (47.6)	5.08 (129)	8.98 (228)	6.81 (173)
3/4"	7.25 (184)	7.62 (194)	1.94 (49.25)	2.31 (58.75)	5.08 (129)	8.98 (228)	6.81 (173)
1"	7.25 (184)	7.75 (197)	2.11 (53.95)	2.43 (61.9)	5.08 (129)	8.98 (228)	6.81 (173)
1" 1/2	8.75 (222)	9.25 (235)	2.50 (63.5)	3.06 (77.8)	5.04 (128)	8.90 (226)	7.28 (185)
2"	10.00 (254)	10.50 (267)	3.00 (76.2)	3.25 (82.55)	5.04 (128)	8.90 (226)	7.28 (185)
3"	11.75 (298.5)	12.5 (318)	3.75 (95.25)	4.12 (104.75)	7.36 (187)	12.05 (306)	10.04 (260)
4"	13.88 (352.5)	14.50 (368)	4.5 (114.3)	5.00 (127)	7.24 (184)	12.09 (307)	12.20 (310)
6"	17.75 (451)	18.62 (473)	5.5 (139.7)	6.25 (158.75)	10.20 (259)	14.61 (371)	14.61 (371)
8"	21.38 (543)	22.38 (568)	6.75 (171.45)	7.5 (190.5)	11.18 (284)	15.59 (396)	15.59 (396)

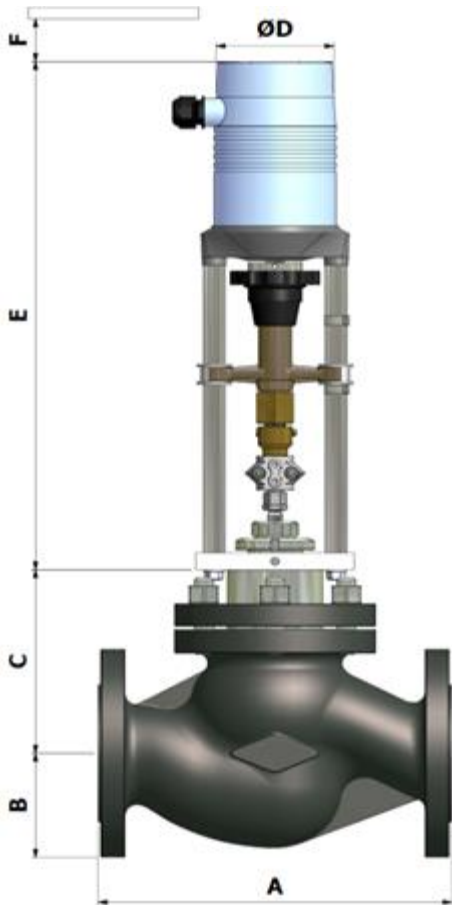

SIZE	C (mm)		
	Otturatore Bilanciato / Balanced Trim		
	STD	Soffietto Bellows	Alettato/prolungato Finned /Extended
2"	6.18 (157)	10.07 (256)	8.42 (214)
3"	9.05 (230)	13.70 (348)	11.10 (282)
4"	9.64 (245)	14.48 (368)	12.20 (310)
6"	14.01 (356)	18.74 (476)	15.67 (398)
8"	14.96 (380)	19.68 (500)	16.61 (422)

TIPO / TYPE	ØD Inches (mm)	E Inches (mm)	F Inches (mm)
MC 103 (24 Vac)	3.94 (100)	14.80 (376)	5.51 (140)
MC 103 (230 Vac)	3.94 (100)	15.78 (401)	5.51 (140)
MC 163 (24 Vac)	3.94 (100)	16.85 (428)	5.51 (140)
MC 163 (230 Vac)	3.94 (100)	17.83 (453)	5.51 (140)
MC 253 / MC 503	5.31 (135)	26.38 (670)	7.87 (200)
MC 403	5.31 (135)	26.38 (670)	7.87 (200)
MC 1003 / MC 1503	5.31 (135)	30.31 (770)	7.87 (200)

ACCESSORI E VARIANTI DISPONIBILI

- Grado di protezione IP65
- Ritrasmissione 4÷20 mA
- Finecorsa
- Motori elettrici con molla di ritorno
- Motori elettrici Ex-ia & Ex-d

OPTIONS AND ACCESSORIES

- Enclosure protection IP65
- 4÷20 mA feedback
- Limit switches
- Spring return electric actuator
- Ex-ia & Ex-d electric actuator

SCHEDA PRODOTTO DATA SHEET

DSM-L20-A2
ED-17-12

TERMINALI A SALDARE

TERMINALI A SALDARE

A inches (mm)	C inches (mm)			C inches (mm)		
	Otturatore Standard / Standard Trim			Otturatore Bilanciato / Balanced Trim		
	STD	Soffietto Bellows	Alettato/prolungato Finned /Extended	STD	Soffietto Bellows	Alettato/prolungato Finned /Extended
7.46 (189.5)	5.08 (129)	8.98 (228)	6.81 (173)			
7.62 (194)	5.08 (129)	8.98 (228)	6.81 (173)			
7.75 (197)	5.08 (129)	8.98 (228)	6.81 (173)			
9.25 (235)	5.04 (128)	8.90 (226)	7.28 (185)			
10.50 (267)	5.04 (128)	8.90 (226)	7.28 (185)	6.18 (157)	10.07 (256)	8.42 (214)
12.5 (318)	7.36 (187)	12.05 (306)	10.04 (260)	9.05 (230)	13.70 (348)	11.10 (282)
14.50 (368)	7.24 (184)	12.09 (307)	12.20 (310)	9.64 (245)	14.48 (368)	12.20 (310)
18.62 (473)	10.20 (259)	14.61 (371)	14.61 (371)	14.01 (356)	18.74 (476)	15.67 (398)
22.38 (568)	11.18 (284)	15.59 (396)	15.59 (396)	14.96 (380)	19.68 (500)	16.61 (422)

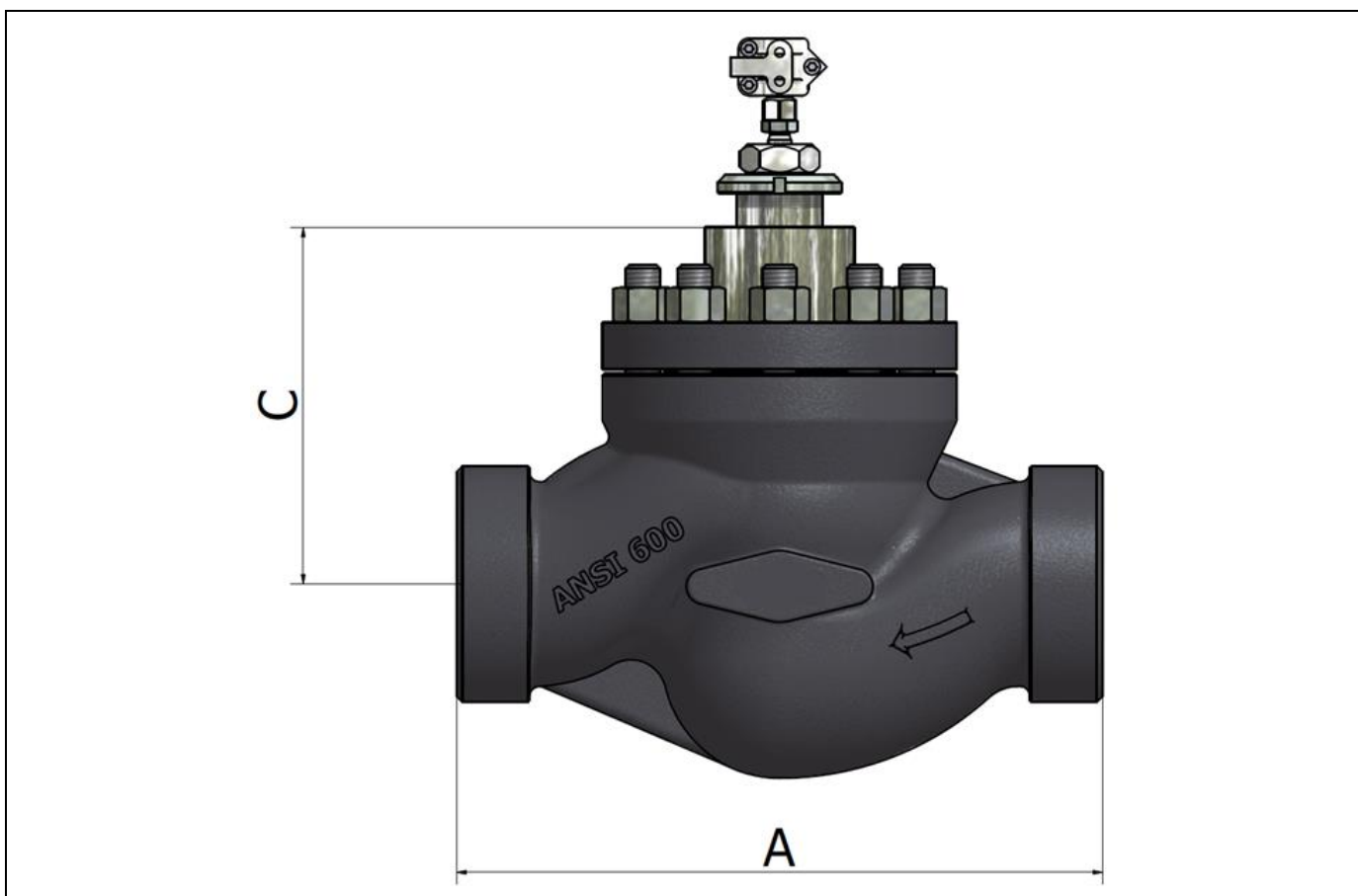

PESI CORPI VALVOLA

VALVE BODY WEIGHT

INCH	Standard (Kg)		Alettato (Kg) Finned (Kg)		Prolungato (Kg) Extended (Kg)		Soffietto (Kg) Bellows (Kg)	
	WCC	CF8M	WCC	CF8M	WCC	CF8M	WCC	CF8M
1/2"	8,5	8,8	8,8	9,1	9,1	9,3	9,7	10
3/4"	9,5	9,8	9,8	10,1	10,1	10,3	10,7	11
1"	10,2	10,5	10,7	11	10,9	11,2	11,3	11,6
1" 1/2"	18,2	19,3	18,8	19,9	19,3	20,5	19,9	21
2"	22,7	23,3	23,3	23,9	23,8	24,4	24,3	25
3"	47	47,8	48,9	49,7	50,1	50,9	51,2	52
4"	83,2	84,6	86,7	88,2	87,9	89,4	87,1	88,6
6"	199,7	301,8	205,2	207,4	207,6	209,8	206,4	208,6
8"	365,2	368,4	370,8	374,1	373,2	376,5	371,9	375,2

**SCHEDA PRODOTTO
DATA SHEET**

**DSM-L20-A2
ED-17-12**

PESI ATTUATORI PNEUMATICI

PNEUMATIC ACTUATOR WEIGHT

TIPO / TYPE	SEGNALE / SIGNAL [psi]	ATTUATORE ACTUATOR [Kg]	VOLANTINO MANUALE HAND WHEEL [Kg]
AP 23	3 ÷ 15	7.3	1
	6 ÷ 18	7.4	
	6 ÷ 30	7.3	
	15 ÷ 60	7.8	
AP 28	3 ÷ 15	9.7	1
	6 ÷ 18	9.8	
	6 ÷ 30	9.6	
	15 ÷ 60	11.5	
AP 34 / AP 35	3 ÷ 15	14.7	2.1
	6 ÷ 18	14.9	
	6 ÷ 30	15	
	15 ÷ 60	17.4	
AP 43 / AP 44	3 ÷ 15	26	7,1
	6 ÷ 18	26.5	
	6 ÷ 30	26.8	
	15 ÷ 60	32.2	
AP 47	15 ÷ 60	57.4	21
AP 61	15 ÷ 60	168	21
OP 10	ON-OFF	7.5	-
OP 16	ON-OFF	12.5	-

PESI ATTUATORI ELETTRICI

ELECTRIC ACTUATOR WEIGHT

TIPO / TYPE	24 Vac [Kg]	230 Vac [Kg]
MC 103	2.5	2.5
MC 163	4	4
MC 253	7.4	8.6
MC 403	9.5	9.5
MC 503	7.4	8.6
MC 1003	11.5	11.5
MC 1503	11.5	11.5

LEGISLAZIONE EUROPEA

Accessorio a pressione valutato con Modulo H1, Direttiva 2014/68/UE.

EUROPEAN LEGISLATION

Pressure equipment evaluated according to Module H1, Directive 2014/68/UE.

SCHEDA PRODOTTO DATA SHEET

DSM-L20-A2
ED-17-12

CODIFICAZIONE / ORDERING INFORMATION

Valvole di regolazione / Regulation Valves		L20-A2 1/2" - 3/4" ANSI 150 / 300									
Numero di codice / Code number	L20-A2										
Attacco al processo / Process connection											
1/2" ANSI		A									
3/4" ANSI		B									
1" ANSI		C									
1" 1/2 ANSI		D									
2" ANSI		E									
3" ANSI		F									
4" ANSI		G									
6" ANSI		H									
8" ANSI		I									
Speciale / Special		Z									
Corpo / Body											
ASTM A216 WCC	ANSI600		C1								
ASTM A216 WCC	ANSI600		C2								
ASTM A352 LCC	ANSI600		C3								
ASTM A351 CF8M	ANSI600		S1								
A Richiesta / On request			Z9								
Cappello / Bonnet											
Standard WCC				S1							
Standard CF8M				S2							
Alettato / Finned - Acciaio al Carbonio / Carbon Steel	T>200 [°C]			F1							
Allungato / Extended - Acciaio al Carbonio / Carbon Steel	-29<T<-5 [°C]			E1							
Alettato / Finned - Acciaio Inox / Stainless Steel	T>200°C [°C]			F2							
Allungato / Extended - Acciaio Inox / Stainless Steel	-90<T<-5 [°C]			E2							
Tenuta Stelo / Stem tightness											
HT200 - Premistoppa / Stuffing Box	T≤200 [°C]			HT2							
HTS300 - Premistoppa / Stuffing Box	T≤400 [°C]			HTS							
Green Pack	T≤450 [°C]			GP1							
GR20 - Premistoppa Grafite / Graphite Stuffing Box	T≤400 [°C]			GR2							
ZEB20 - Soffietto Inox / Stainless Steel Bellows				ZEB							
Passaggio / Passing											
Ridotto / Reduced							1				
Pieno / Full							2				
Tipo otturatore / Shutter type											
TOP GUIDE - Tenuta metallica / Metallic sealing					Cl. IV			T1			
TOP GUIDE - Tenuta / Sealing PTFE/GR					Cl. VI			T2			
TOP GUIDE - Tenuta / Sealing Stellittata					Cl. IV			T3			
TOP GUIDE - Indurimento con Nitrurazione salina / Hardening with nitriding salt					Cl. IV			T4			
Bilanciato / Balanced								BL			
Gabbia antirumore e/o anticavitazione / Anti-noise and/or anti-cavitation cage											
Si / Yes									Y		
Non richiesta / Not required									N		
Conformità NACE / NACE conformity											
Si / Yes										Y	
Non richiesta / Not required										N	
Verniciatura / Painting											
RAL 7021 - T≤150 [°C]											P1
RAL 9005 - 150<T≤250 [°C]											P2
RAL 9006 - 250<T≤400 [°C]											P3
Per ambienti marini / Marine type											P4